

Our In-building antennas are designed to provide excellent coverage solutions in order for external Public Safety Radio Frequencies to propagate within buildings, tunnels or public use environments.

Our antennas can cover single or multiple frequency bands. We offer a wide variety of antennas with Fire Retardant 6200 Kydex radomes. These materials are designed for In-building applications and inside public transport vehicles such as underground trains, vans, buses and trains. They meet the recommended fire safety practices of both the Federal Transit Administration (FTA) and the Federal Rail Administration (FRA) for smoke emission and flammability as tested under ASTM E-662 and ASTM E-162.

The F-3741 has been designed for mounting with a ground plane on a concrete surface. This is a requirement for meeting full bandwidth specifications. Polycarbonate tubing is used for the radome on the F-3741. It's a flame resistant and self-extinguishing material.

Electrical Specifications	F-3741
Frequency Range, MHz	VHF / UHF/ 760-960
Nominal Gain	Unity
Bandwidth: 2.0:1 VSWR, MHz	
138-174	8
406-512	64
764-890	126
806-960	154
1800-1990	N/A
2400-3000	N/A
Polarization	Vertical
Pattern	Omnidirectional
Power Rating, Watts	50
Nominal Impedance, Ohms	50
Radome	Polycarbonate
Standard Termination	N Male
Mechanical Specifications	F-3741
Length, in (mm)	11.25 (286.88)
Diameter, in (mm)	0.65 (16.575)
Weight, lbs (kg)	N/A
Mounting hardware	Included

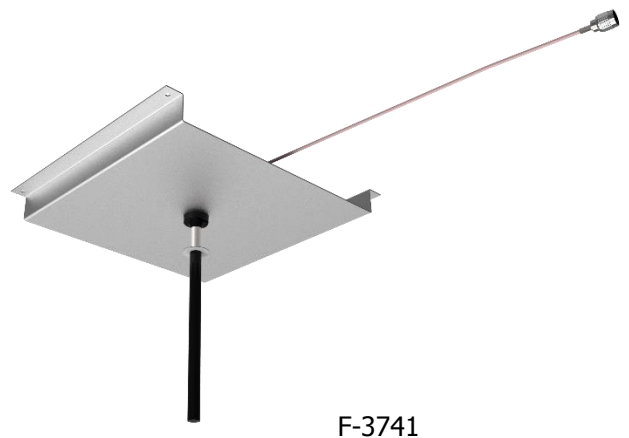

F-3741